

Datasheet

5550 & 5550G Mechanical Vibration Switches

Overview

Model 5550 and 5550G mechanical switches provide basic, economical vibration protection by means of a simple and highly reliable "over center" snap action mass and spring mechanism. In the presence of sufficient vibration along the switch's sensitive axis, the switch snaps from a stable "untripped" state to a stable "tripped" state, allowing automatic machinery shutdown or alarming when excessive vibration occurs. Once tripped, the switch must be returned to its untripped state via its local reset plunger (5550 only), or via voltage applied to its remote reset coil (standard on 5550G, optional on 5550). A single set of silver-plated SPDT relay contacts are provided as standard for connecting the switch to a machine control or annunciation circuit. An option for DPDT contacts is also available, and for extremely corrosive environments, gold-plated relay contacts may be ordered.

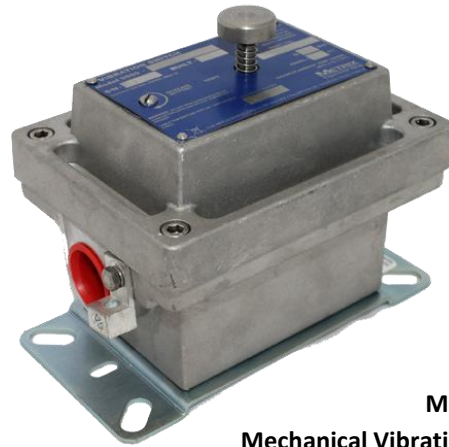

Model 5550
Mechanical Vibration Switch



Model 5550G
Mechanical Vibration Switch

Key Feature Comparison

	5550	5550G
IECEx / ATEX Flameproof up to Gas Group Rating IIB + H ₂	Optional	Standard
IECEx / ATEX Flameproof up to Gas Group Rating IIC	Not Available	Standard
CSA / UL / cUL Explosion Proof Ratings for Div 1 areas	Optional	Not Available
Remote Reset / Startup Delay	Optional	Standard
Setpoint Adjustment Screw	Externally Accessible	Internally Accessible
Reset	Local (Std) and Remote (Opt)	Remote Only
NEMA 4 / IP66 Rating	Standard	Standard
NEMA 4X / IP66 Rating	Optional	Standard
Mounting Footprint	Rectangular, 4-hole	Rectangular, 2-hole
CE Mark	Standard	Standard

Selection Criteria

The 5550 and 5550G use identical internal mechanisms, but differ in their housing styles, mounting footprints, hazardous area ratings, and externally accessible features.

While the housing used with the 5550G permits its use in the more highly explosive IIC gas group, it is not available with a local reset plunger or with an externally accessible setpoint adjustment screw. The 5550G also occupies a larger mounting footprint. For these reasons, the 5550 is generally the preferred choice except in applications where the IIC gas group is present.

Setpoint Adjustment

The switch's trip point can be adjusted between 0 and 16 g's (peak) in increments of approx. 1 g (1/8th turn of setpoint adjustment screw). This adjustment screw is externally accessible on the 5550. On the 5550G, the housing's cover must be removed to access the adjustment screw.

Remote Reset / Startup Delay

A remote reset / startup delay feature is standard on the 5550G and optional on the 5550. When the switch's reset terminals are energized, a solenoid is activated. This solenoid will reset the switch (if in its tripped state) and then hold it in this untripped state for approximately 30 seconds*, after which normal operation of the switch resumes. This feature is useful for machines that exhibit higher-than-normal vibration during startup and need to suppress tripping functions until normal operating speeds and conditions have been reached. The holding strength of this solenoid must be properly specified at time of ordering to ensure it can force the switch into an untripped position and hold it there for the duration of the

startup delay, even in the presence of high vibration levels (see ordering option C).

*NOTE: It is not possible to indefinitely prolong the duration of the startup delay by continuously applying voltage to the reset terminals. The duration is set at the factory for approximately 30 seconds and uses a thermistor circuit. Consult the manual for additional details and recommendations for using both the reset and startup delay features.



NOTE: Mechanical vibration switches rely on inertial forces (acceleration) to actuate the trip mechanism. Thought should be given to the amount of seismic acceleration that will occur under machinery malfunction conditions and whether it will be sufficient to reliably actuate a mechanical switch. In particular, the relationship between acceleration, velocity, and displacement is such that at low frequencies, very large peak-to-peak displacements (in excess of 100mm) are required to generate the acceleration amplitudes (1g or greater) detectible by a mechanical switch. Care should be taken when measuring vibration frequencies below 10 Hz (600 rpm) to understand the levels of structural displacement, velocity, and acceleration that are generated at the frequency(ies) of interest. These should be compared to maximum allowable vibration levels for the machine or structure to determine whether the setpoint adjustment resolution of a mechanical switch will provide suitable results for the application.

In some instances, seismic velocity may be a better measurement. It also has the advantage of allowing integration to displacement units when total structural displacement is of interest. When seismic velocity or displacement measurements are more suitable for the application, a mechanical switch cannot provide these measurements. Instead, Metrix can provide electronic vibration switches, 4-20 mA transmitters, or stand-alone monitoring systems. Consult with your nearest Metrix sales professional who can review your application and assist with selection of the proper instrumentation.

Specifications

All specifications are at +25C (+77° F) unless otherwise noted.

5550	
	
Amplitude Range	0 to 16 g pk NOTE: Reset coil holding strength (option C) may limit the usable amplitude range of the switch when the startup delay feature is required.
Frequency Range	0 – 60 Hz (0 – 3600 rpm)
Setpoint Adjustment	Location Externally Accessible
	Resolution 1g (approximately 1/8 th turn of adjustment screw where one full turn ≈ 8g)
	Range 0 – 100% of amplitude range
	Wiring Entries One (3/4" NPT or M20 x 1.5 – see option E)
Local Reset	Manual plunger-style pushbutton on switch housing
Temperature Limit	-40° C to +70° C (-40° F to +158° F)
Mounting	4-hole rectangular in various dimensional options (see Figure 1 and option E)

Remote Electrical Reset / Startup Delay	Optional (see option D). Applying a momentary voltage to the reset terminals will reset the switch to its untripped position. Applying a persistent voltage to the reset terminals will suppress the trip mechanism from actuating for the duration of voltage application or 30 seconds, whichever is less (a thermistor circuit limits the maximum delay time).	
Reset Coil Holding Strength	<ul style="list-style-type: none"> • 2g, 5g, or 10g (see option C). This option dictates the highest g-levels under which remote reset / startup delay capabilities will still operate. 	
Enclosure Material	<ul style="list-style-type: none"> • Copper-free cast aluminum (standard NEMA 4 version) • Copper-free cast aluminum with clear epoxy coating (optional NEMA 4X version) 	
Environment Rating	<ul style="list-style-type: none"> • NEMA 4 / IP66 (standard) • NEMA 4X / IP66 (optional) 	
Hazardous Area Rating	Explosion Proof / Flameproof (see ordering option A)	
Agency Certifications	CSA / UL / cUL Class I Div 1 Grps B,C,D Class II Div 1 Grps E,F,G	
	ATEX / IECEX Ex d IIB + H ₂ T6	
	INMETRO BR-Ex d IIB + H ₂ T6	
Weight	1.8 kg (4.0 lbs)	
Contacts	Type	
	<ul style="list-style-type: none"> • SPDT (standard) • DPDT (optional) 	
	Plating Material	
	<ul style="list-style-type: none"> • Silver (standard) • Gold (optional) 	
	Ratings	
	Silver-plated	Gold-plated
	15A @ 125-480 Vac 1/4 hp @ 125 Vac 1/8 hp @ 250 Vac 0.5A @ 125 Vdc 0.25A @ 250 Vdc	1A @ 125 Vac

Specifications

All specifications are at +25C (+77° F) unless otherwise noted.

5550G	
	
Amplitude Range	0 to 16 g pk NOTE: Reset coil holding strength (option C) may limit the usable amplitude range of the switch when the startup delay feature is required.
Frequency Range	0 – 60 Hz (0 – 3600 rpm)
Setpoint Adjustment	Location Internally Accessible (cover must be removed to access)
	Resolution 1g (approximately 1/8 th turn of adjustment screw where one full turn ≈ 8g)
	Range 0 – 100% of amplitude range
Wiring Entries	Two (3/4" NPT only – see Figure 2)
Local Reset	Not available (must use remote electrical reset)
Temperature Limit	-40° C to +70° C (-40° F to +158° F)
Mounting	2-hole rectangular (see Figure 2)

Remote Electrical Reset / Startup Delay	Standard (see option D). Applying a momentary voltage to the reset terminals will reset the switch to its untripped position. Applying a persistent voltage to the reset terminals will suppress the trip mechanism from actuating for the duration of voltage application or 30 seconds, whichever is less (a thermistor circuit limits the maximum delay time).	
Reset Coil Holding Strength	2g, 5g, or 10g (see option C). This option dictates the highest g-levels under which remote reset / startup delay capabilities will still operate.	
Enclosure Material	Cast aluminum with blue epoxy coating	
Environment Rating	NEMA 4X / IP66	
Hazardous Area Rating	Flameproof	
Agency Certifications	ATEX / IECEx Ex d IIC T6	
Weight	2.5 kg (5.5 lbs)	
Contacts	Type	
	<ul style="list-style-type: none"> • SPDT (standard) • DPDT (optional) 	
	Plating Material	
	<ul style="list-style-type: none"> • Silver (standard) • Gold (optional) 	
	Ratings	
	Silver-plated	Gold-plated
	15A @ 125-480 Vac 1/4 hp @ 125 Vac 1/8 hp @ 250 Vac 0.5A @ 125 Vdc 0.25A @ 250 Vdc	1A @ 125 Vac

Ordering Information



5550-ABC-DEF
5550 Mechanical Vibration Switch

A **Hazardous Area Rating^{1,2,3}**

0	None, silver contacts
1	CSA/UL/cUL Explosion Proof, silver contacts Class I, Div 1, Groups C,D Class II, Div 1, Groups E,F,G
2	CSA/UL/cUL Explosion Proof, silver contacts Class I, Div 1, Groups B,C,D Class II, Div 1, Groups E,F,G
3	OBSOLETE, specify A=4 instead ⁸
4	ATEX / IECEx Flameproof Ex d IIB+H ₂ T6 silver contacts
5	Same as A=0 but gold contacts
6	Same as A=1 but gold contacts
7	Same as A=2 but gold contacts
8	OBSOLETE, specify A=9 instead ⁸
9	Same as A=4 but gold contacts
10	OBSOLETE, specify A=11 instead ⁸
11	INMETRO Flameproof, BR-Ex d IIB + H ₂ T6

B **Relay Contacts^{1,2}**

1	SPDT, Silver, 15A
2	DPDT, Silver, 15A
3	SPDT, Gold, 1A
4	DPDT, Gold, 1A

C **Reset / Startup Delay Coil Holding Strength⁷**

1	5 g
2	2 g ⁴
3	10 g

D **Reset / Startup Delay Coil Voltage**

0	None ⁷
1	115 Vac
2	230 Vac
3	24 Vdc ⁴
4	115 Vdc

E **Wiring Entry / Mounting Hole Pattern^{3,5}**

1	3/4" NPT / Metrix 5173 or 5175
2	3/4" NPT / Metrix 5097, VS-2 EX, or 366
3	3/4" NPT / Metrix 5078 or 365
4	M20 x 1.5 / Metrix 5097, VS-2 EX, or 366
6	M20 x 1.5 / Metrix 5173 or 5175
7	3/4" NPT / Metrix or PMC-BETA 440
8	M20 x 1.5 / Metrix 5078 or 365

F **Environmental Rating⁶**

0	NEMA 4 / IP66
1	NEMA 4X / IP66

NOTES:

- Options A=0 through A=4 are only compatible with B=1 or B=2. Options A=5 through A=9 are only compatible with B=3 or B=4.
- INMETRO approvals (A=11) available with silver relay contacts only (B=1 or B=2)
- UL / cUL approvals require tapered threads for conduit and are not compatible with option E=4, 6, or 8. CSA approvals are compatible with all E options (1-8).
- When options C=2 and D=3 are simultaneously specified (2g, 24Vdc reset coil), the switch sensitive axis (see Figure 1) MUST be oriented vertically with the cover facing up. This coil lacks sufficient holding strength to support the trip plate when the switch is mounted horizontally or upside down. The switch may be mounted at any orientation for all other options.
- Consult Figure 1 for mounting plate dimensions corresponding to E options.
- If left blank, option 0 is provided.
- When D=0 (no reset /startup delay coil), the C option is ignored regardless of which value is selected. All switches ship with a full-scale range of approximately 16gs.
- Options A=3, A=8, and A=10 were all for Ex d IIB T6. These are now replaced by the A=4, A=9, and A=11, respectively, which reflect the same approvals but with addition of the H₂ gas group.

Ordering Information



5550-ABC-DEF 5550G Mechanical Vibration Switch

A	<input type="checkbox"/>	Hazardous Area Rating
	G	ATEX / IECEx Ex d IIC T6(Ta -40C to +70C) Gb Ex tD A20 IP66
B	<input type="checkbox"/>	Relay Contacts
	1	SPDT, Silver, 15A
	2	DPDT, Silver, 15A
	3	SPDT, Gold, 1A
	4	DPDT, Gold, 1A
C	<input type="checkbox"/>	Reset / Startup Delay Coil Holding Strength
	1	5 g
	2	2 g ¹
	3	10 g
D	<input type="checkbox"/>	Reset / Startup Delay Coil Voltage
	1	115 Vac
	2	230 Vac
	3	24 Vdc ¹
	4	115 Vdc
E	<input type="checkbox"/>	Wiring Entry / Mounting Plate Hole Pattern²
	9	3/4" NPT (2 places)
F	<input type="checkbox"/>	Environmental Rating
	2	NEMA 4X / IP66

NOTES:

- When options C=2 and D=3 are simultaneously specified (2g, 24Vdc reset coil), the switch sensitive axis (see Figure 2) MUST be oriented vertically with the cover facing up. This coil lacks sufficient holding strength to support the trip plate when the switch is mounted horizontally or upside down. The switch may be mounted at any orientation for all other options.
- Consult Figure 2 for mounting dimensions.

Additional Documentation

Description	Metrix Document Number
5550 Hazardous Area Installation Manual	M8905
5550G Hazardous Area Installation Manual	100356
5550 / 5550G Operation & Maintenance Manual	1231558

Wiring Diagram

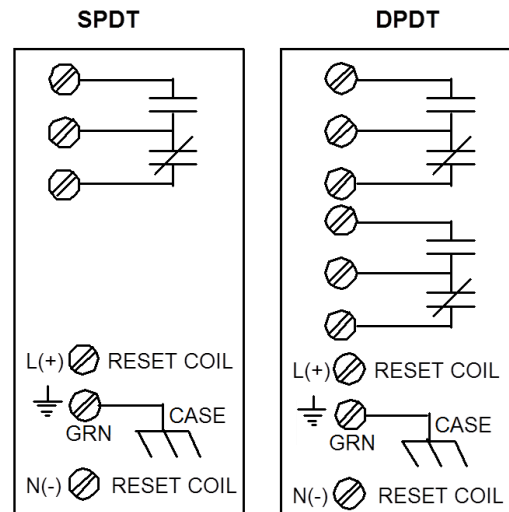

NOTES:

SPDT contacts are standard; DPDT contacts are optional. Reset coil is standard on 5550G, optional on 5550.

Outline Diagrams

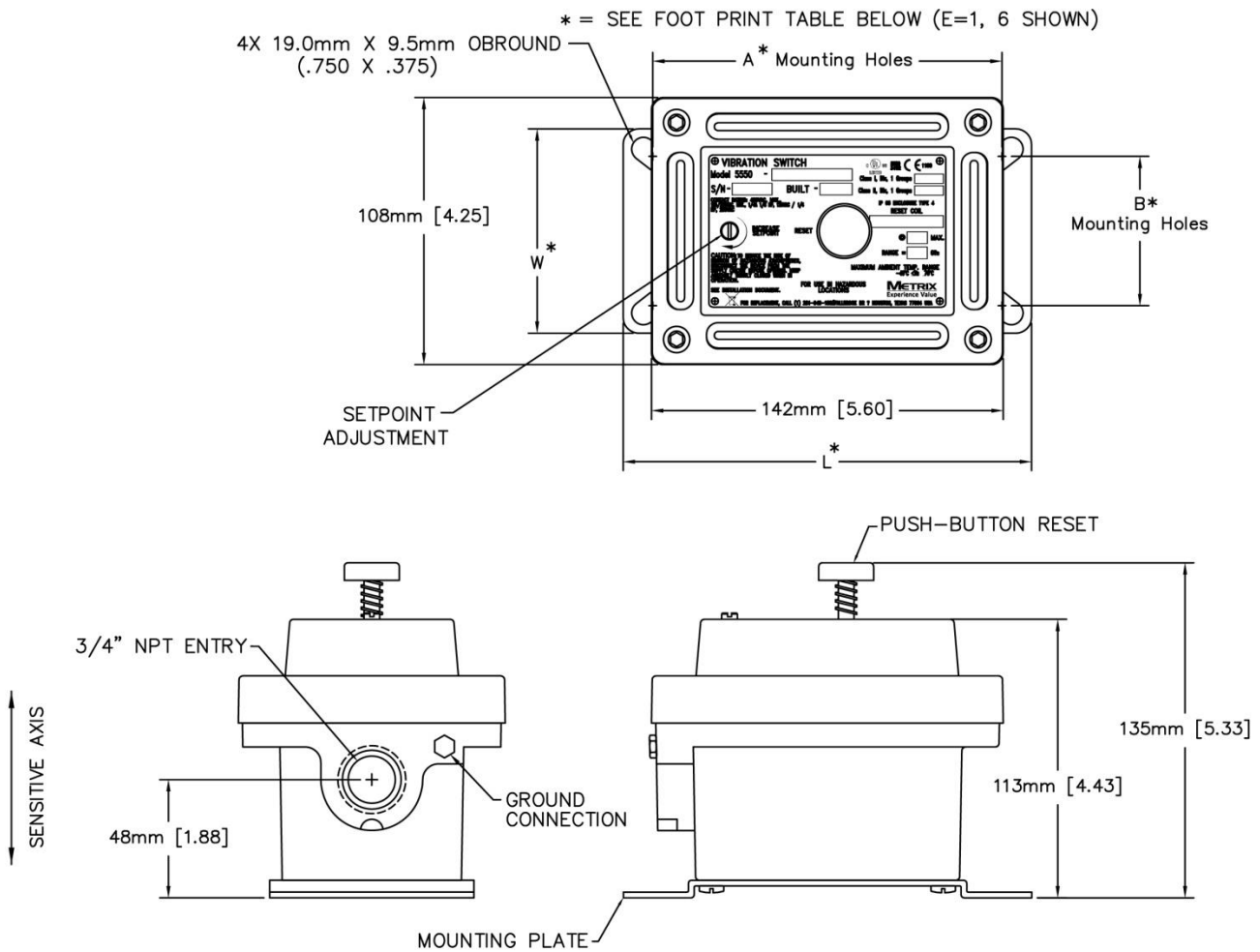

FOOT PRINT TABLE				
	(L)	(W)	(A)	(B)
E=1, 6	165mm [6.50]	83mm [3.25]	141mm [5.56]	59mm [2.33]
E=2, 4, 5	121mm [4.75]	152mm [6.00]	79mm [3.12]	118mm [4.63]
E=3, 8	165mm [6.50]	121mm [4.75]	136mm [5.37]	92mm [3.62]
E=7	114mm [4.50]	127mm [5.00]	71mm [2.80]	108mm [4.25]

Figure 1 – 5550 Mechanical Vibration Switch.

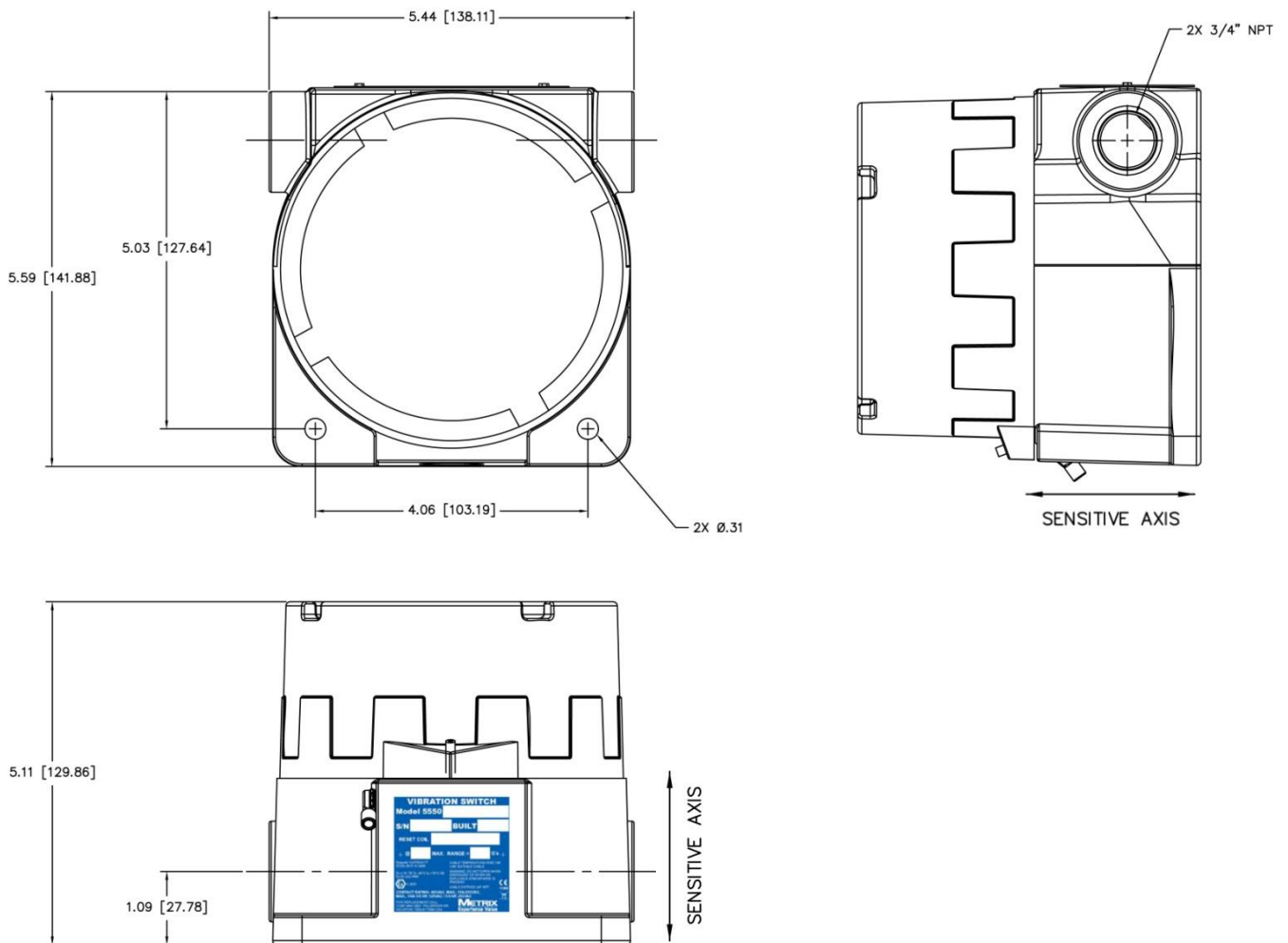

Figure 2 – 5550G Mechanical Vibration Switch.

METRIX
Experience Value

Metrix Instrument Company

北京公司

信德迈科技(北京)有限公司 CNMEC Technology Company

地址：北京市朝阳区胜古中路2号金基业大厦201室

邮编：100029

电话：010-8428 2935,6441 3876,8428 9077

手机：139 1096 2635 QQ:1152366120

传真：010-8428 8762

Http：//www.cnmec.biz

E-mail：sales@cnmec.biz

西安公司

西安嘉岳自动化技术有限公司 Garye Automation Company

地址：陕西西安市凤城二路天地时代广场B座23层22312室

邮编：710016

电话：029 - 8610 8648 , 029 - 8621 4592

手机：153 1975 9129,153 1975 2262

传真：029 - 8610 6806 QQ:1750597616

Http://www.garye.cn

E-mail：sales@garye.cn