



aerospace
climate control
electromechanical
filtration
fluid & gas handling
hydraulics
pneumatics
process control
sealing & shielding



204, 209, 304 and 309 Series

Fluid Control for Food & Beverage, Commercial, Industrial, Instrumentation, Transportation and HVAC Markets



ENGINEERING YOUR SUCCESS.

204, 209, 304 and 309 Series

2 Way and 3 Way Small Direct Acting Solenoid Valves and Cartridge Valves



The new Series 204 and 304 offers customers solenoid valves to meet the most demanding applications. This new product line is a series of direct acting solenoid valves for most gas and liquid (including light oils) application requirements.

These Parker valves readily meet application system needs in today's *mobile, commercial, industrial, medical and instrumentation markets*.

Product Features:

- State of the art operator performance = long life and maximized pressure ratings
- Patent pending NEMA 4X coil with rotating hub for easier conduit assembly
- Standard with FKM* elastomer seals
- High temperature watertight coil designs are offered
- AC & DC coils are interchangeable on all pressure vessels
- Service without the need for special tools
- Economy models available for less demanding applications
- Certified agency approvals at high ambient and media temperatures

* FKM is the ASTM designation for fluoroelastomer.



Series 209 and 309 are cartridge versions of the Series 204 and 304 intended for manifold installations.

Unlike typical solenoid operators used with manifolds, the cartridge approach simplifies manifold machining. There are less parts to handle, and assembly time is less. These benefits combined add up to lower installed cost when considering the manifold approach.

Product Features:

- Space saving approach
- Less manifold machining equals lower manifold cost
- No manifold orifices to machine or press in
- Cartridge valves are 100% tested
- No loose parts: sleeve, plunger, spring and orifice are pressed together as one unit
- Available with all 204 and 304 coils



Medical and Instrumentation Markets



Industrial Markets



Mobile Markets

204, 209, 304 and 309 Technical Specifications

Mechanical Characteristics

Body: 303 Stainless Steel
 Sleeve: Stainless Steel
 Plunger: Stainless Steel
 Seals: FKM*
 Shading Ring: Copper
 Spring: Stainless Steel

Mounting

Any orientation is permissible

Operating Characteristics

ΔP minimum 0 psid
 ΔP maximum see tables
 Max. Fluid Viscosity (300 SSU)

Environmental Temp. Ranges

AC Ambient Temperature Range
 *32°F (0°C) to 135°F (57°C)

DC Ambient Temperature Range
 * 32°F (0°C) to 125°F (52°C)

AC Media Temperature Range
 * 32°F (0°C) to 240°F (116°C)

DC Media Temperature Range
 * 32°F (0°C) to 240°F (116°C)

* In the absence of moisture, applications as low as -20°F (-29°C) are possible.

Compatible Fluids

Lubricated Air, Non-Lubricated Air, Inert Gases, Water, Petroleum Products and additional fluids compatible with the materials of construction. Pressure ratings apply to all compatible fluids within stated temperature ranges.

Agency Approvals/Compliance



ENGLISH UNITS						METRIC UNITS					
Port Size NPT	Orifice Size (in.)	Cv Factor	Operating Pressure Differential (psi)			Pressure Vessel Number	Orifice Size (mm)	Kv Factor (m ³ /h)	Operating Pressure Differential (bar)		
			Min.	Max. AC	Max. DC				Min.	Max. AC	Max. DC
2 Way Direct Acting Valves (NC)											
1/8	3/64	0.06	0	950	390	20CC02EV4	1.2	0.05	0	65	27
1/8	1/16	0.10	0	625	255	20CC02GV4	1.6	0.09	0	43	17.5
1/8	5/64	0.15	0	450	180	20CC02JV4	2.0	0.13	0	31	12.5
1/8	3/32	0.22	0	320	130	20CC02LV4	2.4	0.19	0	22	9
1/8	7/64	0.28	0	245	100	20CC02MV4	2.7	0.24	0	17	7
1/8	1/8	0.32	0	175	60	20CC02PV4	3.2	0.28	0	12	4
1/8	5/32	0.38	0	100	30	20CC02QV4	4.0	0.33	0	7	2
2 Way Direct Acting Valves (NO)											
1/8	1/32	0.02	0	375	375	20CF02AV4	0.8	0.02	0	26	26
1/8	3/64	0.06	0	230	230	20CF02EV4	1.2	0.05	0	16	16
1/8	1/16	0.10	0	150	150	20CF02GV4	1.6	0.09	0	10	10
1/8	5/64	0.14	0	105	105	20CF02JV4	2.0	0.12	0	7	7
1/8	3/32	0.20	0	80	80	20CF02LV4	2.4	0.17	0	5.5	5.5
2 Way Cartridge Valves (NC)											
N/A	3/64	0.06	0	950	390	209CL5EV4	1.2	0.05	0	65	27
N/A	1/16	0.10	0	625	255	209CL5GV4	1.6	0.09	0	43	17.5
N/A	5/64	0.15	0	450	180	209CL5JV4	2.0	0.13	0	31	12.5
N/A	3/32	0.22	0	320	130	209CL5LV4	2.4	0.19	0	22	9
N/A	7/64	0.28	0	245	100	209CL5MV4	2.7	0.24	0	17	7
N/A	1/8	0.32	0	175	60	209CL5PV4	3.2	0.28	0	12	4
N/A	5/32	0.38	0	100	30	209CL5QV4	4.0	0.33	0	7	2
2 Way Cartridge Valves (NO)											
1/8	1/32	0.02	0	375	375	209FL5AV4	0.8	0.02	0	26	26
1/8	3/64	0.06	0	230	230	209FL5EV4	1.2	0.05	0	16	16
1/8	1/16	0.10	0	150	150	209FL5GV4	1.6	0.09	0	10	10
1/8	5/64	0.13	0	105	105	209FL5JV4	2.0	0.12	0	7	7
1/8	3/32	0.17	0	80	80	209FL5LV4	2.4	0.17	0	5.5	5.5

* FKM is the ASTM designation for fluoroelastomer.

304 and 309 Technical Specifications

Port Size NPT	ENGLISH UNITS								METRIC UNITS							
	BODY		SLEEVE		Operating Pressure Differential (psi)			Pressure Vessel Number	BODY		SLEEVE		Operating Pressure Differential (bar)			
	Orifice Size (in.)	Cv Factor	Orifice Size (in.)	Cv Factor	Min.	Max. AC	Max. DC		Orifice Size (mm)	Kv Factor (m ³ /h)	Orifice Size (mm)	Kv Factor (m ³ /h)	Min.	Max. AC	Max. DC	
3 Way Direct Acting Valves (NC)																
1/8	1/32	0.02	1/32	0.02	0	250	250	30CC02AV4	0.8	0.02	0.8	0.02	0	17	17	
1/8	3/64	0.05	3/64	0.05	0	200	200	30CC02EV4	1.2	0.04	1.2	0.04	0	14	14	
1/8	1/16	0.09	1/16	0.10	0	130	130	30CC02GV4	1.6	0.08	1.6	0.08	0	9	9	
1/8	5/64	0.15	5/64	0.14	0	90	90	30CC02JV4	2.0	0.13	2.0	0.12	0	6	6	
1/8	3/32	0.19	3/32	0.20	0	75	75	30CC02LV4	2.4	0.16	2.4	0.17	0	5	5	
1/8	7/64	0.25	3/32	0.20	0	50	50	30CC02MV4	2.7	0.22	2.4	0.17	0	3.5	3.5	
1/8	1/8	0.32	3/32	0.20	0	40	40	30CC02PV4	3.2	0.28	2.4	0.17	0	3	3	
1/8	5/32	0.38	3/32	0.20	0	25	25	30CC02QV4	4.0	0.33	2.4	0.17	0	1.5	1.5	
3 Way Direct Acting Valves (NO)																
1/8	1/32	0.02	1/32	0.02	0	375	375	30CF02AV4	0.8	0.02	0.8	0.02	0	26	26	
1/8	3/64	0.05	3/64	0.05	0	230	230	30CF02EV4	1.2	0.04	1.2	0.04	0	16	16	
1/8	1/16	0.09	1/16	0.10	0	150	150	30CF02GV4	1.6	0.08	1.6	0.08	0	10	10	
1/8	5/64	0.15	5/64	0.14	0	105	105	30CF02JV4	2.0	0.13	2.0	0.12	0	7	7	
1/8	3/32	0.19	3/32	0.20	0	80	80	30CF02LV4	2.4	0.16	2.4	0.17	0	5.5	5.5	
3 Way Direct Acting Valves (U)																
1/8	1/32	0.02	1/32	0.02	0	200	200	30CU02AV4	0.8	0.02	0.8	0.02	0	14	14	
1/8	3/64	0.05	3/64	0.05	0	150	150	30CU02EV4	1.2	0.05	1.2	0.04	0	10	10	
1/8	1/16	0.09	1/16	0.10	0	100	100	30CU02GV4	1.6	0.08	1.6	0.08	0	7	7	
1/8	5/64	0.15	5/64	0.14	0	70	70	30CU02JV4	2.0	0.13	2.0	0.12	0	5	5	
1/8	3/32	0.19	3/32	0.20	0	50	50	30CU02LV4	2.4	0.16	2.4	0.17	0	3.5	3.5	
1/8	7/64	0.25	3/32	0.20	0	40	40	30CU02MV4	2.7	0.22	2.4	0.17	0	3	3	
1/8	1/8	0.32	3/32	0.20	0	30	30	30CU02PV4	3.2	0.28	2.4	0.17	0	2	2	
1/8	5/32	0.38	3/32	0.20	0	20	20	30CU02QV4	4.0	0.33	2.4	0.17	0	1.5	1.5	
3 Way Cartridge Valves (NC)																
1/8	1/32	0.02	1/32	0.02	0	250	250	309CL5AV4	0.8	0.02	0.8	0.02	0	17	17	
1/8	3/64	0.05	3/64	0.05	0	200	200	309CL5EV4	1.2	0.04	1.2	0.04	0	14	14	
1/8	1/16	0.09	1/16	0.10	0	130	130	309CL5GV4	1.6	0.08	1.6	0.08	0	9	9	
1/8	5/64	0.15	5/64	0.14	0	90	90	309CL5JV4	2.0	0.13	2.0	0.12	0	6	6	
1/8	3/32	0.19	3/32	0.20	0	75	75	309CL5LV4	2.4	0.16	2.4	0.17	0	5	5	
1/8	7/64	0.25	3/32	0.20	0	50	50	309CL5MV4	2.7	0.22	2.4	0.17	0	3.5	3.5	
1/8	1/8	0.32	3/32	0.20	0	40	40	309CL5PV4	3.2	0.28	2.4	0.17	0	3	3	
1/8	5/32	0.38	3/32	0.20	0	25	25	309CL5QV4	4.0	0.33	2.4	0.17	0	1.5	1.5	
3 Way Cartridge Valves (NO)																
1/8	1/32	0.02	1/32	0.02	0	375	375	309FL5AV4	0.8	0.02	0.8	0.02	0	26	26	
1/8	3/64	0.05	3/64	0.05	0	230	230	309FL5EV4	1.2	0.04	1.2	0.04	0	16	16	
1/8	1/16	0.10	1/16	0.10	0	150	150	309FL5GV4	1.6	0.08	1.6	0.08	0	10	10	
1/8	5/64	0.13	5/64	0.14	0	105	105	309FL5JV4	2.0	0.13	2.0	0.12	0	7	7	
1/8	3/32	0.19	3/32	0.20	0	80	80	309FL5LV4	2.7	0.16	2.4	0.17	0	5.5	5.5	
3 Way Cartridge Valves (U)																
1/8	1/32	0.02	1/32	0.02	0	200	200	309UL5AV4	0.8	0.02	0.8	0.02	0	14	14	
1/8	3/64	0.05	3/64	0.05	0	150	150	309UL5EV4	1.2	0.04	1.2	0.04	0	10	10	
1/8	1/16	0.10	1/16	0.10	0	100	100	309UL5GV4	1.6	0.08	1.6	0.08	0	7	7	
1/8	5/64	0.13	5/64	0.14	0	70	70	309UL5JV4	2.0	0.13	2.0	0.12	0	5	5	
1/8	3/32	0.19	3/32	0.20	0	50	50	309UL5LV4	2.4	0.16	2.4	0.17	0	3.5	3.5	
1/8	7/64	0.25	3/32	0.20	0	40	40	309UL5MV4	2.7	0.22	2.4	0.17	0	3	3	
1/8	1/8	0.31	3/32	0.20	0	30	30	309UL5PV4	3.2	0.28	2.4	0.17	0	2	2	
1/8	5/32	0.36	3/32	0.20	0	20	20	309UL5QV4	4.0	0.33	2.4	0.17	0	1.5	1.5	

Dimensional Drawings for the Series 204, 209, 304 and 309

204 2 Way Normally Closed

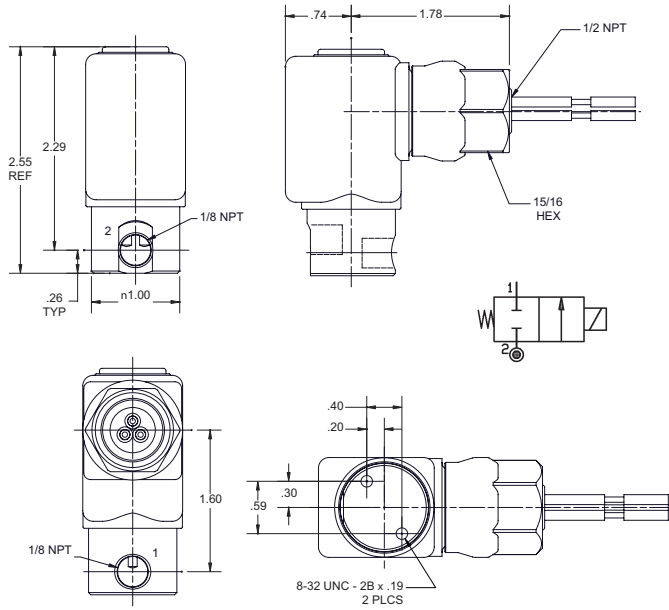

204 2 Way Normally Open

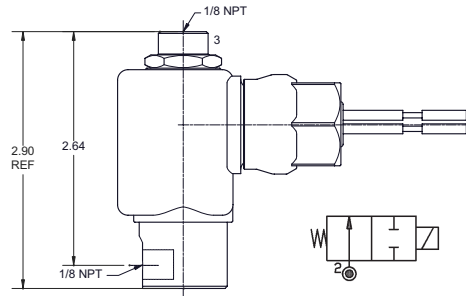

304 3 Way Normally Closed/Normally Open/Universal

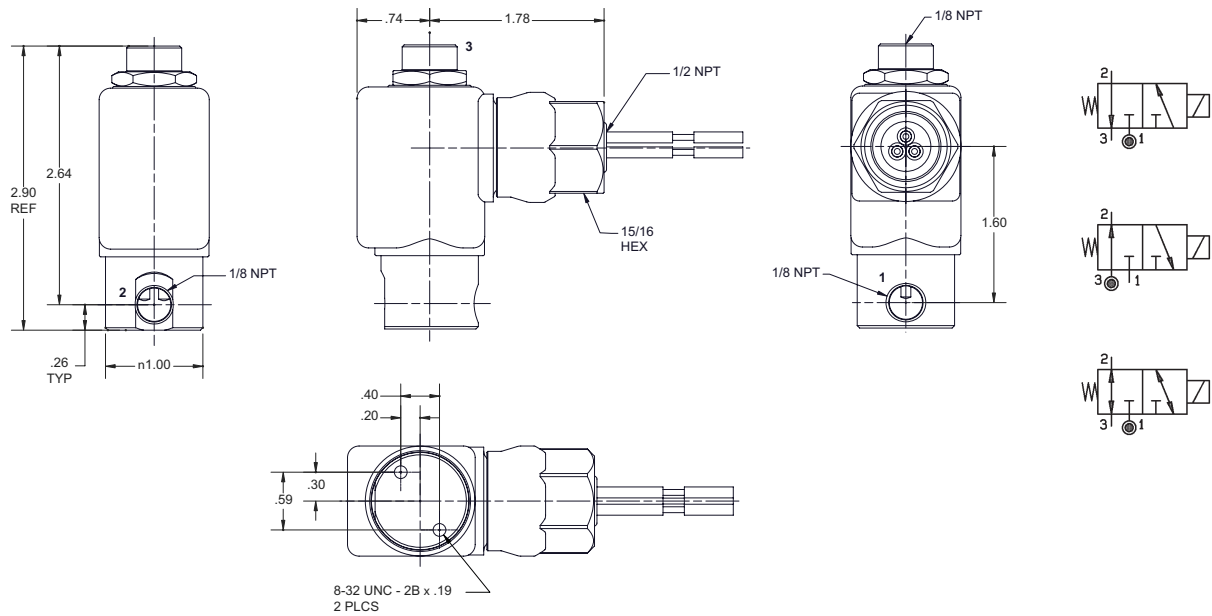

209 2 Way Normally Closed

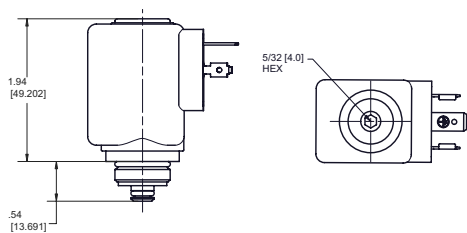

309 3 Way Normally Closed/Normally Open/Universal

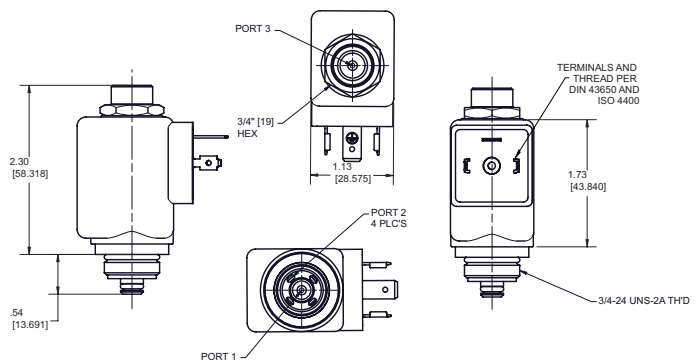

How to Order

Modular Units: Our solenoid valves can be ordered in two parts: pressure vessel and solenoid coil.

To order modular units, order the pressure vessel and mix and match 3 different coil styles to match your application requirement.

The available modular coils consist of the following coils displayed on the next page:

- C4 conduit coil
- B4 leaded coil
- D6 DIN coil

TO ORDER PRESSURE VESSEL

- Choose your pressure vessel from the Technical Specification pages. The pressure vessel will contain the required coil retaining nut.

TO ORDER COIL

- Go to the Encapsulated Watertight Coil Design section on the opposite page in the brochure.
- Go to Voltage Code chart on the same page and select voltage
- Add Voltage Code to end of Coil Code

* The coil assembly will contain the O-ring seals.

* Coils carry the following approval:

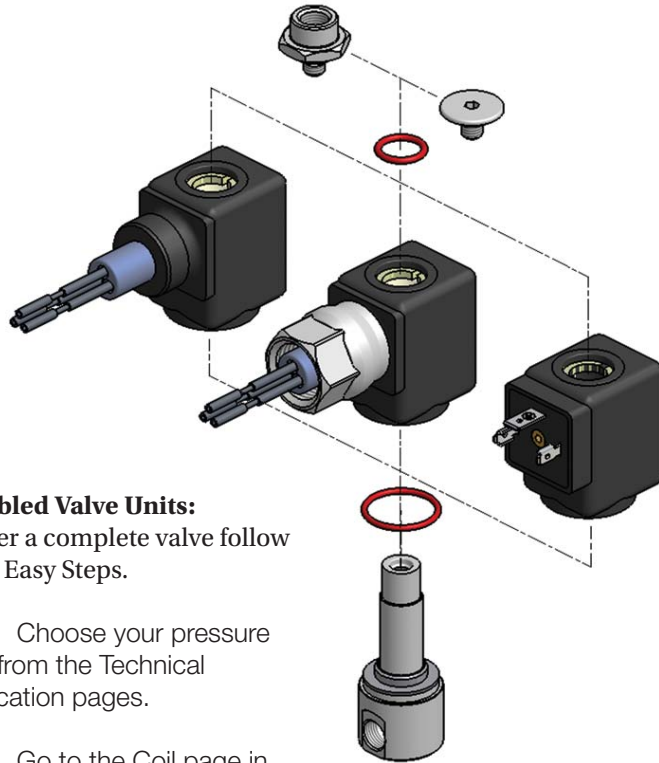

Assembled Valve Units:

To Order a complete valve follow these 3 Easy Steps.

Step 1: Choose your pressure vessel from the Technical Specification pages.

Step 2: Go to the Coil page in the brochure. Look at either the Encapsulated or Conventional Coil sections. Choose your coil and apply the 2 digit code to the end of the pressure vessel number.

Step 3: Lastly, go to the Voltage Code chart located on the coil page and select the one digit voltage code, add the code to the end of the coil code.



Coils

Encapsulated Watertight Designs. Available as Modular Coils or for Fully Assembled Valves

Conduit Coil
Coil Code: C4



Construction:
 - Class F
 - 18" lead wires
 - Ground wire
 - 1/2" NPT conduit hub
 - NEMA 4X, IP65 protection
 AC: 10 Watts except 2 Way
 Normally Closed is 8.5 Watts
 DC: 8 Watts

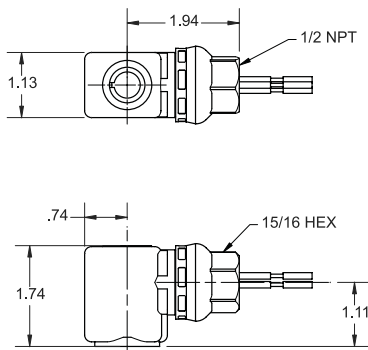

Leaded Coil
Coil Code: B4



Construction:
 - Class F
 - 18" lead wires
 - Ground wire
 AC: 10 Watts except 2 Way
 Normally Closed is 8.5 Watts
 DC: 8 Watts

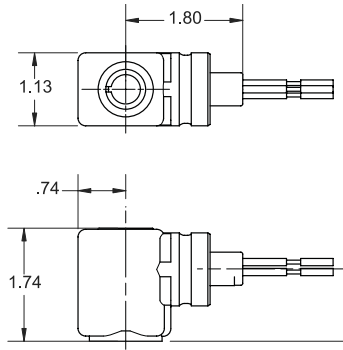

DIN Coil
Coil Code: D6



Construction:
 - Class H
 - DIN 43650A/ISO 4400 configuration
 - NEMA 4X, IP65 protection with a suitable plug and gasket
 AC: 10 Watts except 2 Way
 Normally Closed is 8.5 Watts
 DC: 8 Watts

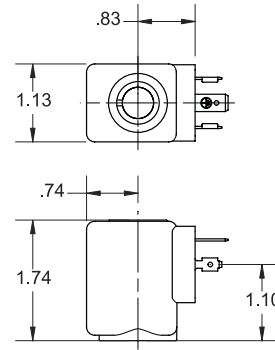

Conventional Coil & Enclosures for Fully Assembled Valves Only

Leaded Coil
Coil Code: L2



Construction:
 - Open frame enclosure
 - Molded leaded coil
 - Class F
 - 18" leads- 2 wire
 AC: 10 Watts except 2 Way
 Normally Closed is 8.5 Watts
 DC: 8 Watts

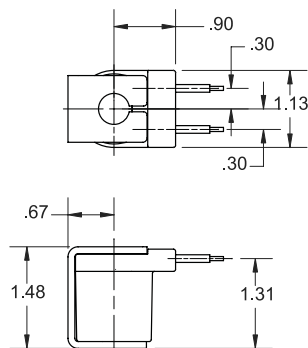

Tab Coil
Coil Code: T2



Construction:
 - Open frame enclosure
 - 1/4" tab terminals
 - Class F
 AC: 10 Watts except 2 Way
 Normally Closed is 8.5 Watts
 DC: 8 Watts

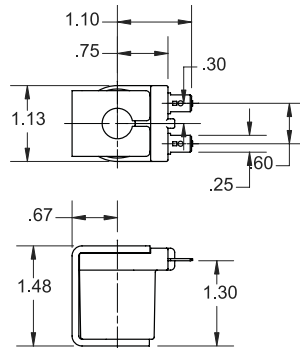

Voltage Codes:

- A= 12VDC
- B= 24VDC
- E= 24/60
- F= 120/60, 110/50
- G= 240/60, 220/50

Worldwide Division Headquarters

North America

Fluid Control Division

95 Edgewood Avenue
New Britain, CT 06051

Europe

Fluid Control Division-Europe

16 Ch. Faubourg-de-Cruseilles
CH- 1227 Caourage, Geneva

Additional product information
can be found on our website:

www.parker.com/fcd

Questions on our product line,
please call: 1 800 valve05



联系方式：

信德迈科技(北京)有限公司 CNMEC Technology Company

地址：北京市朝阳区望京SOHO-T1-C座2115室邮编：100102

*Tel: 010-8428 2935 | * Fax: 010-8428 8762

*手机：139 1096 2635（微信同号）

*电子邮件：sales@cnmec.biz

主页：<http://www.cnmec.biz>